

Wildfire 400 Series

WF-402F Long-Throw™ 400 Watt Ultraviolet Flood Fixture

This State-of-the-art Ultraviolet projector offers both value and performance. Its powerful throw, quiet operation and smooth even light distribution, has made the Wildfire 400 watt flood the world's best selling UV lighting fixture.

Features:

- Heavy Duty Corrosion Resistant Aluminum Housing
- Durable Black Powder Coat Finish
- Stainless Steel Hardware
- Hinged Lens Door for Easy Lamp Access
- Safety Cutoff Switch for Safe Re-lamping
- Digital Lamp Life Meter

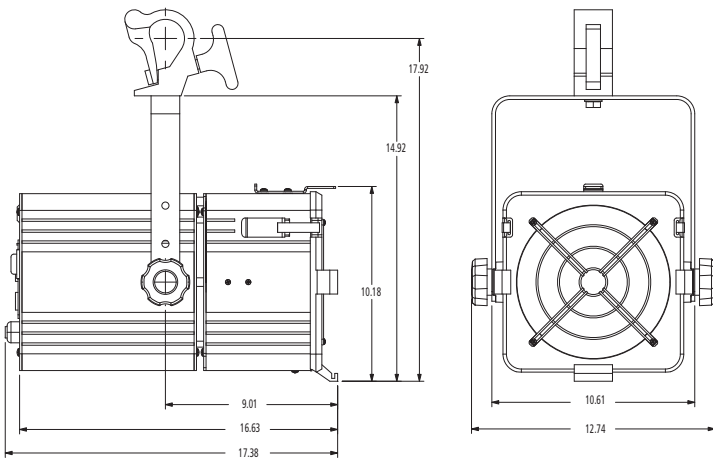

WF-402F Photometrics Chart

90° Flood

	Distance in Feet/Meters										
	10/3.05	20/6.10	30/9.14	40/12.19	50/15.24	60/18.29	70/21.33	80/24.38	90/27.43	100/30.48	110/33.53
Beam Diameter Feet	20	40	60	80	100	120	140	160	180	200	220
Beam Diameter Meters	6.10	12.19	18.29	24.38	30.48	36.57	42.67	48.77	54.86	60.96	67.05
Peak UV-A Intensity $\mu\text{W}/\text{cm}^2$	116	31	14.1	7.9	5.1	3.6	2.6	1.9	1.6	1.3	1

Specifications:

Ballast	Magnetic or Electronic Power Factor > 92%
Rating	Magnetic 120 VAC / 60 Hz / 5 Amps Max / 400W (See ordering example for additional electrical configurations) Electronic 220VAC / 50-60 Hz / 2.0 Amps Max / 400W
Lamp	Wildfire 400 Watt IronArc™ Metal Halide, Model LMP-400D (1000 Hr. Rated)
Beam	90° Flood
Reflector	Laser Cut, Specular Hammertone Aluminum
Lens	8" UV-A Transmission Filter Glass
Peak Spectral Transmission	350-365nm
Weight	35.25 lbs / 16.00 kg (Mag.) 23.70 lbs / 10.80 kg (Elec.)
Accessory Bracket	10" / 25.4cm Bracket Assembly

Standard Equipment:

- Lamp (LMP-400D)
- Pipe Mounting Clamp (ACC-0026)
- Safety Cable (ACC-0027)

Accessories:

- 10" Barn Doors (ACC-0002)
- 10" Dowser (ACC-0015)

WF-402F

Ordering Example (Select desired item from each column)

Model	Lamp Wattage	Photometrics	Electrical	Options	Accessories
WF	402	F	F	DC	BD
Wildfire	402	F-Flood		DC-DMX Control	
			F- 100V/50Hz (Mag.) G- 100V/60Hz (Mag.) H- 120V/50Hz (Mag.) I- 120V/60Hz (Mag.) 2- 220V/50-60HZ (Elec.)		BD-Barn Door DW-Dowser



Wildfire Lighting & Visual Effects

5200 West 83rd Street Los Angeles, California 90045 USA 310.645.7787 800.937.8065 fax 310.645.9009 www.wildfirefx.com mail@wildfirefx.com