

LIGHT DUTY
TRUSS
12" x 12" PLATED

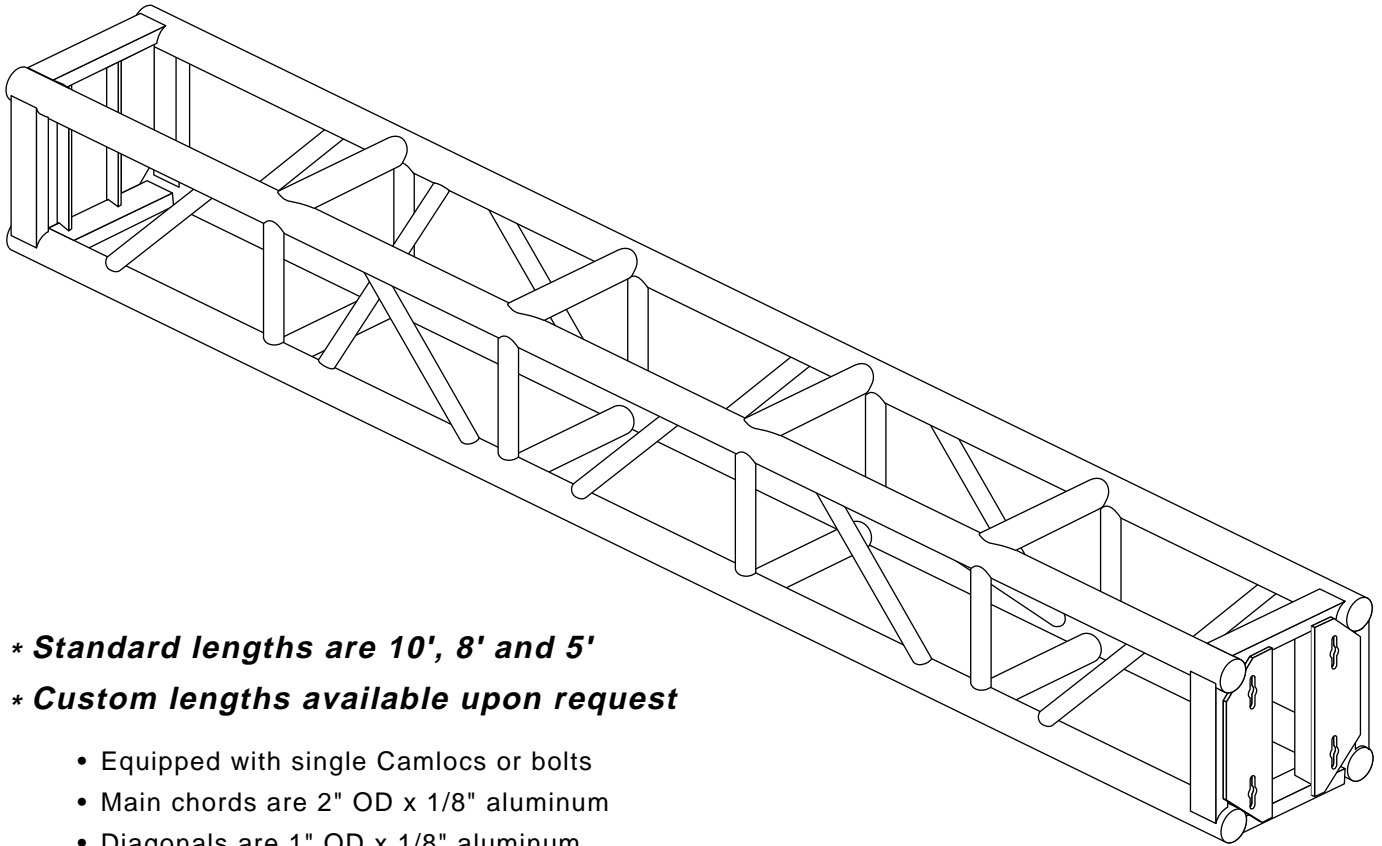

- * **Standard lengths are 10', 8' and 5'**
- * **Custom lengths available upon request**

- Equipped with single Camlocs or bolts
- Main chords are 2" OD x 1/8" aluminum
- Diagonals are 1" OD x 1/8" aluminum
- Fabricated by certified welders

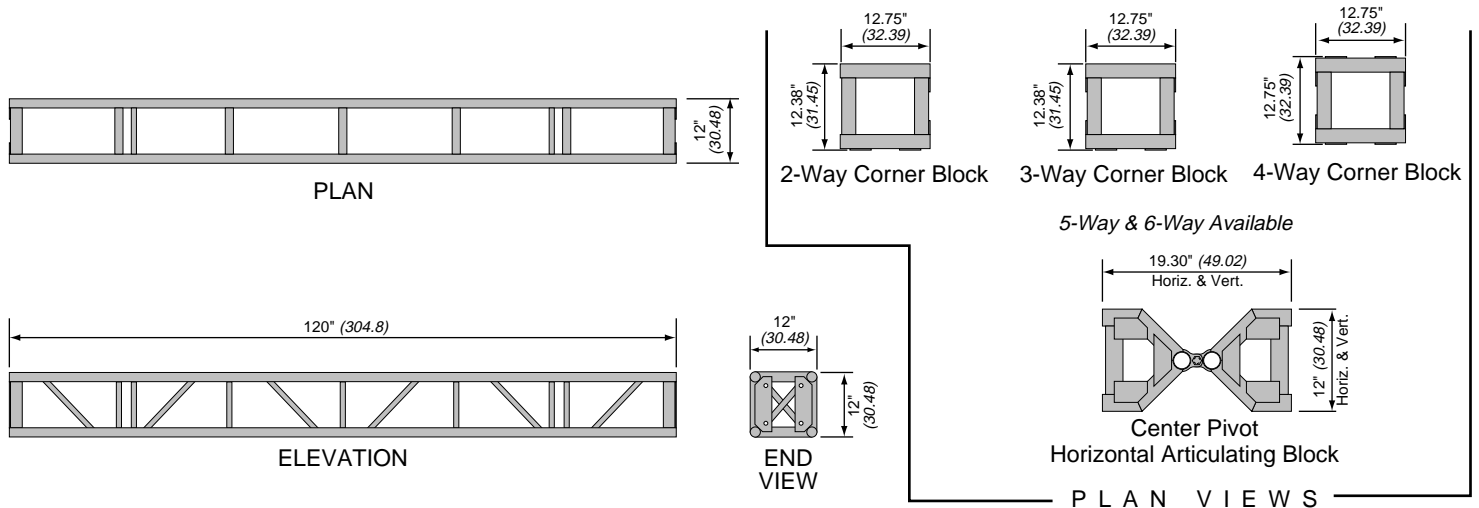

ALLOWABLE LOAD DATA

LIGHT DUTY TRUSS 12" x 12" PLATED

MAXIMUM ALLOWABLE UNIFORM LOADS				MAXIMUM ALLOWABLE POINT LOADS					
				CENTER POINT		THIRD POINT		QUARTER POINT	
Span ft. (mtrs)	Load #/ft.	Load lbs (kgs)	Max Defl. in.	Load lbs (kgs)	Max Defl. in.	Load lbs (kgs)	Max Defl. in.	Load lbs (kgs)	Max Defl. in.
<i>Single Camloc through 3/8" gusset plates</i>									
10 (3.04)	308	3080 (1397)	0.09	1544 (700)	0.08	1158 (525)	0.10	772 (350)	0.09
20 (6.09)	71	1420 (644)	0.38	719 (326)	0.31	539 (244)	0.39	359 (163)	0.36
30 (9.14)	28	840 (381)	0.85	421 (191)	0.72	315 (143)	0.87	210 (95)	0.82
40 (12.21)	12	480 (218)	1.46	254 (115)	1.32	190 (86)	1.54	127 (58)	1.45
<i>5/8" diameter Grade 8 bolts with standard washers through 3/8" gusset plates</i>									
10 (3.04)	446	4460 (2023)	0.14	2231 (1012)	0.11	1673 (759)	0.14	1116 (506)	0.13
20 (6.09)	106	2120 (962)	0.54	1063 (482)	0.44	797 (362)	0.56	531 (241)	0.52
30 (9.14)	43	1290 (585)	1.22	650 (295)	1.01	487 (221)	1.25	325 (147)	1.17
40 (12.21)	21	840 (381)	2.16	426 (193)	1.85	319 (145)	2.21	213 (97)	2.10

Note: Deflections reported in the above tables are maximum expected for full loadings (indoors only).

All loads are based on 10'-0" sections. Other section lengths are available.

Load tables are reprinted from engineering reports developed by Parkhill, Smith & Cooper, Inc., structural engineers, and apply to truss fabricated after December, 1989.

LIGHT DUTY TRUSS 12" x 12" PLATED

Connections are single sets of bolts or Camlocs

Product Description	Item Code	Weight lbs (kgs)
5' LIGHT DUTY TRUSS 12" X 12"	Bolt TRS 1212-060B Cam TRS 1212-060C	36 (16)
8' LIGHT DUTY TRUSS 12" X 12"	Bolt TRS 1212-096B Cam TRS 1212-096C	51 (23)
10' LIGHT DUTY TRUSS 12" X 12"	Bolt TRS 1212-120B Cam TRS 1212-120C	61 (28)
LIGHT DUTY 12" X 12" 2-WAY CORNER BLOCK	Bolt TRS 1212-C2B Cam TRS 1212-C2C	16 (7)
LIGHT DUTY 12" X 12" 3-WAY CORNER BLOCK	Bolt TRS 1212-C3B Cam TRS 1212-C3C	20 (9)
LIGHT DUTY 12" X 12" 4-WAY CORNER BLOCK	Bolt TRS 1212-C4B Cam TRS 1212-C4C	22 (10)
LIGHT DUTY 12" X 12" 5-WAY CORNER BLOCK	Bolt TRS 1212-C5B Cam TRS 1212-C5C	26 (12)
LIGHT DUTY 12" X 12" 6-WAY CORNER BLOCK	Bolt TRS 1212-C6B Cam TRS 1212-C6C	28 (13)
LIGHT DUTY 12" X 12" HORIZ. ARTICULATING BLOCK	Bolt TRS 1212-AHB Cam TRS 1212-AHC	33 (15)
LIGHT DUTY 12" X 12" VERT. ARTICULATING BLOCK	Bolt TRS 1212-AVB Cam TRS 1212-AVC	33 (15)